

THERMICjet® HR



HIGH-TECH FOR A LONG-ESTABLISHED BELGIAN COMPANY

Dacor, a company located in the Belgian city of Gent, has succeeded in bridging the gap between tradition and progress. Schröter developed a hot smoke cooking system for the manufacturer of fine pastries and ham, and the system's airflow is routed in such a way that it ensures the company's products are handled in an absolutely uniform manner.

Klaus Schröter, President of Schröter, is especially pleased when he looks back on the collaboration with the Belgian manufacturer of specialty items: "Dacor's high standards of quality were a challenge that we took on happily and met successfully. Working closely with Dacor's employees, we developed a hot smoke cooking system 5.5 meters high which is used to dry and smoke pre-cooked ham specialties on 11 different levels." Thanks to the sophisticated air duct system, the high-quality products are handled in an absolutely uniform manner. The cooking system, which is designed for use with hanging trolleys up to 3.60 meters high, is sealed with a special inflatable door seal.



High-quality products are handled uniformly on up to 11 levels.



THE CLASSIC APPLICATIONS



COOLING IS OPTIONAL

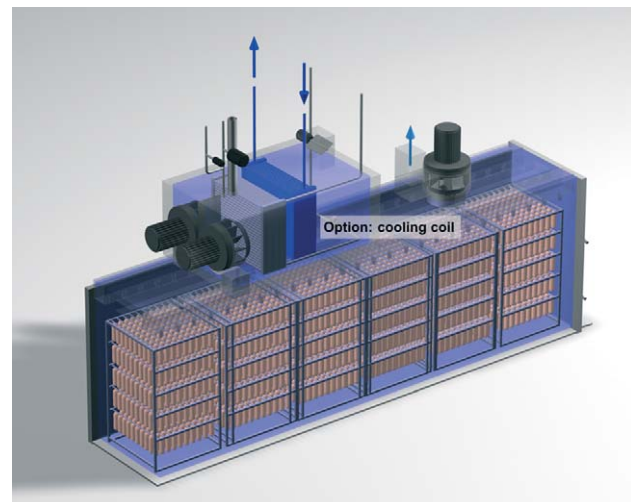

DIFFERENT DOOR SYSTEMS:

- > swing door, double-leaf
- > swing door, single-leaf
- > vertical sliding door
- > sectionized vertical sliding door

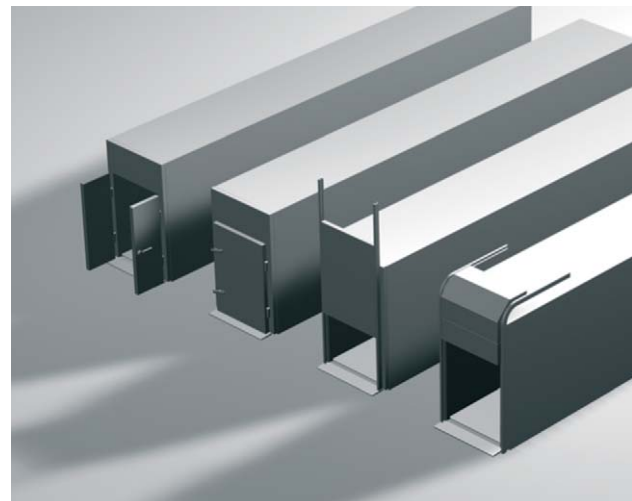

AIR INTAKE SYSTEMS

CLASSIC AIR INTAKE BEHAVIOR:

Vertical intake left and right with variable fan speed.

Return air in the center below the ceiling.

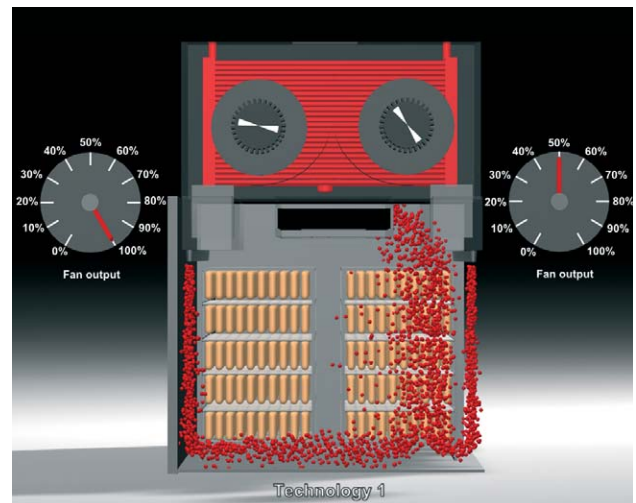

MULTIPLE AIRFLOW SYSTEM:

Vertical and diagonal intake is possible.

Return ducts in the center below the ceiling and in the lower part of the side panels.

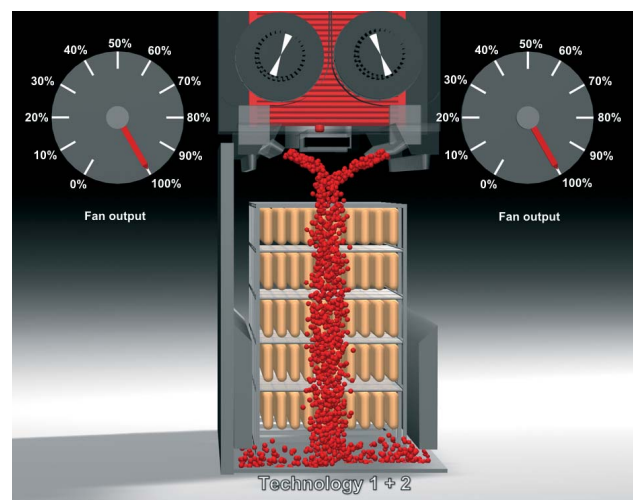
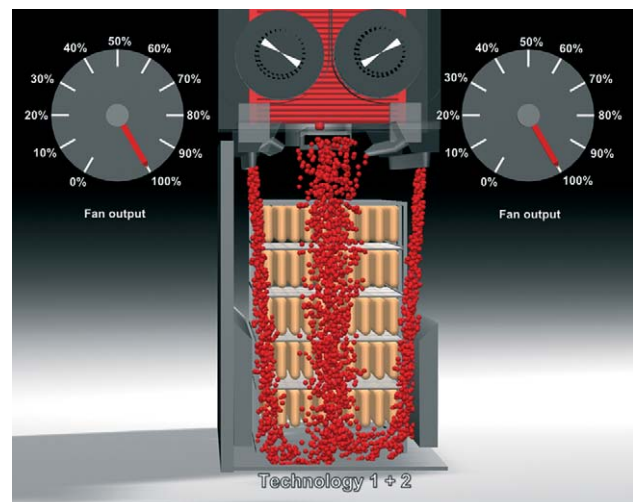

THERMICjet®-HOT SMOKING SYSTEMS: MEASUREMENTS AND CONNECTED LOAD VALUES

SINGLE-ROW SYSTEMS										
MEASUREMENTS	UNIT	1-Wagon	2-Wagon	3-Wagon	4-Wagon	5-Wagon	6-Wagon	7-Wagon	8-Wagon	10-Wagon
Length A (Compact System *)	mm	1200	3100	4200	5510	6610	7930			
Length A (Transit System)	mm		2360	3460	4560	5660	6760	7860	8960	11160
Width B	mm	1440	1760	1760	1760	1760	1760	1760	1760	1760
Height H (Compact System)	mm	2650	2550	2550	2550	2700	2700			
Ceiling Height (Compact System)	mm	3200	3250	3250	3250	3400	3400			
Height H (Transit System)	mm		3500	3500	3500	3800	3800	3800	3800	4000
Ceiling Height (Transit System)	mm		3700	3700	3700	4000	4000	4000	4000	4200
CONNECTED LOAD VALUES	UNIT									
Electricity	kW	4.5	10	10	15	16	21	21	25	34
Heating: Steam, Electricity, Oil, Gas	kW	27	72	96	120	132	156	175	200	250
Humidifying and Cooking: Steam	kg/h	65	125	150	200	250	300	325	350	450
Shower: Cold Water	l/min	18	36	54	72	90	108	125	144	180
Weight	kg	1250	1600	1850	2100	2350	2600	2800	3100	3600

DOUBLE-ROW SYSTEMS										
MEASUREMENTS	UNIT	4-Wagon	6-Wagon	8-Wagon	10-Wagon	12-Wagon	14-Wagon	16-Wagon	18-Wagon	20-Wagon
Length A (Compact System *)	mm	3310	4410	5510	6610	7710	8980	10080	11480	12580
Length A (Transit System)	mm	2360	3460	4560	5660	6760	7860	8960	10060	11160
Width B	mm	2860	2860	2860	2860	2860	2860	2860	2860	2860
Height H (Compact System)	mm	2550	2550	2550	2700	2700	2700	2700	2850	2850
Ceiling Height (Compact System)	mm	3200	3200	3200	3400	3400	3600	3600	3800	3800
Height H (Transit System)	mm	3600	3600	3700	3900	3900	3900	3900	4100	4100
Ceiling Height (Transit System)	mm	3800	3800	3900	4100	4100	4100	4100	4300	4300
CONNECTED LOAD VALUES	UNIT									
Electricity	kW	16	21	25	30	34	42	48	53	65
Heating: Steam, Electricity, Oil, Gas	kW	120	156	200	250	300	350	400	450	500
Humidifying and Cooking: Steam	kg/h	200	300	350	450	525	600	675	750	825
Shower: Cold Water	l/min	72	108	144	180	216	252	288	324	360
Weight	kg	2500	2800	3250	3900	4400	5000	5700	6200	6700

Measurements apply to a trolley size of: 1.0 m x 1.0 m x 2.0 m. Energy input values are the maximum connected load values. Actual usage rates are lower depending on the product. A space approx. 800 mm wide must be left free behind the systems for maintenance purposes.

*Measurement "A" is 500 mm larger in systems heated using oil or gas.

TECHNICAL DETAILS

DIMENSIONAL SKETCH

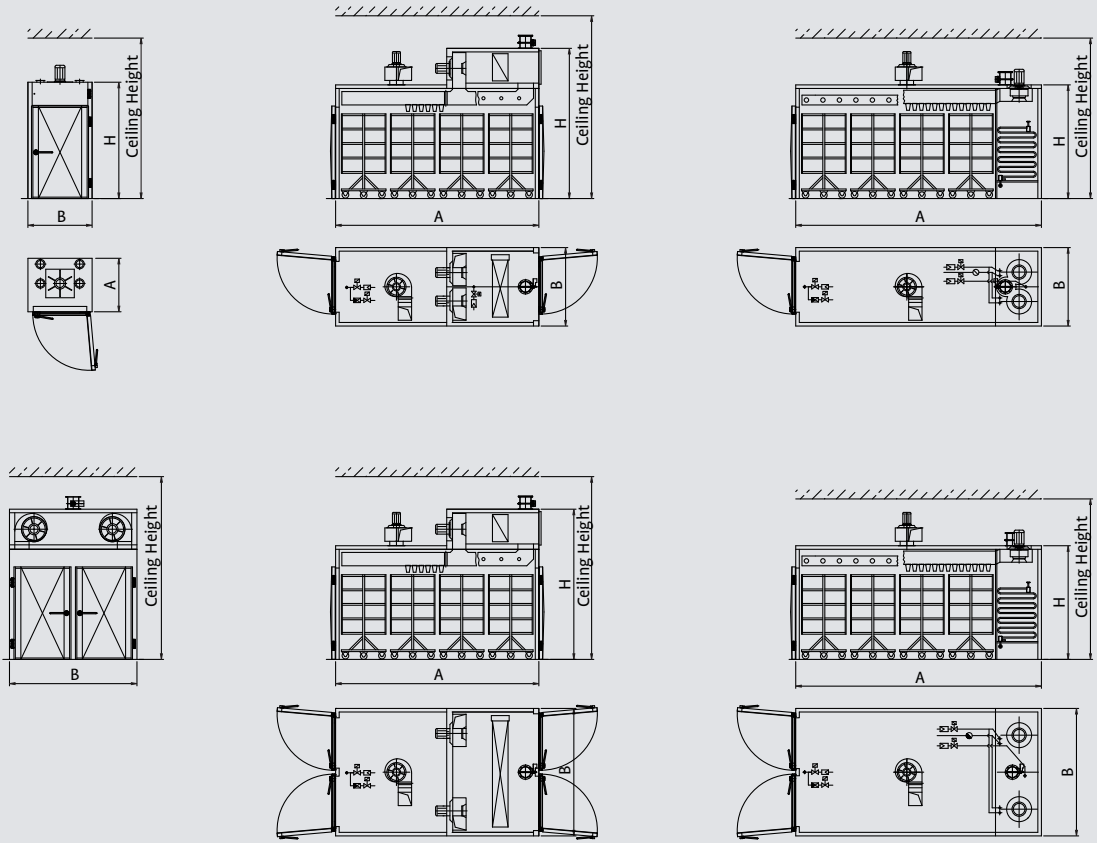

1 TROLLEY – SMALL SYSTEM / SMALL TRADE DESIGN

DIMENSIONAL SKETCH

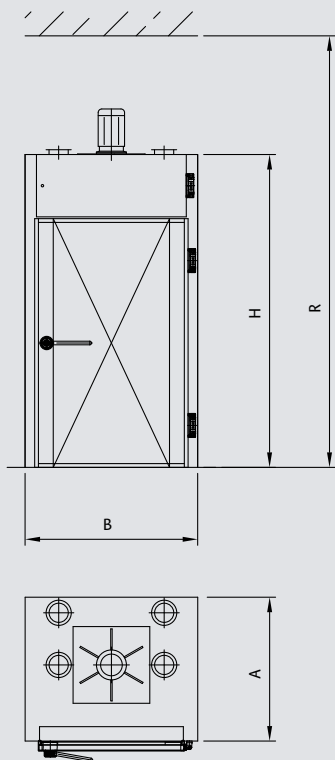

MEASUREMENTS AND CONNECTED LOAD VALUES

		1/1600	1/1800	1/2000
Feasible Processes		HS*	HS*	HS*
MEASUREMENTS	UNIT			
B	mm	1450	1450	1450
A	mm	1200	1200	1200
H	mm	2250	2450	2650
R	mm	2800	3000	3200
CONNECTED LOAD VALUES				
Electricity 220/380 V	kW	4.5	4.5	4.5
Heating:				
Steam, 8 bar	kg/h	40	40	50
Electricity/oil/gas	kW	24	27	27
Humidifying and cooking:				
Steam, 0.5 bar	kg/h	50	55	65
Water		½"	½"	½"
Electr. (for oil/gas heat.)	kW	15	15	15
Shower:				
Water ½"	l/min	24	24	24
Compressed air 6 bar	l/min	3	3	3
Weight	kg	1100	1150	1250

*HS = Hot smoking

1 TROLLEY – JETSMOKER – UNIVERSAL SYSTEM / INDUSTRIAL STANDARD

DIMENSIONAL SKETCH

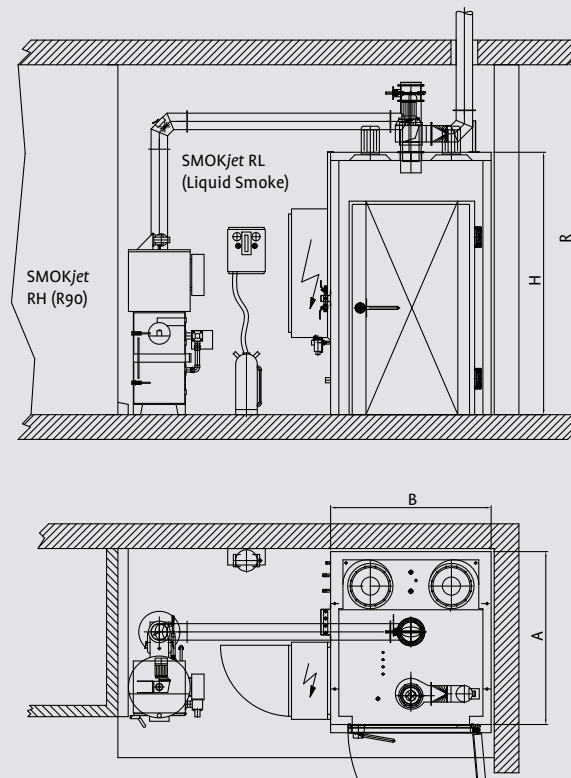

MEASUREMENTS AND CONNECTED LOAD VALUES		
		JetSmoker
Feasible Processes		HS/CS/BA*
MEASUREMENTS	UNIT	
B	mm	1560
A	mm	1680
H	mm	2550
R	mm	3600
CONNECTED LOAD VALUES		
Electricity 220/380 V	kW	5.5
Heating:		
Steam, 8 bar	kg/h	30
Electricity/oil/gas	kW	54
Humidifying and cooking:		
Steam, 0.5 bar	kg/h	65
Water		1/2"
Electr. (for oil/gas heat.)	kW	15
Shower:		
Water 1/2"	l/min	20
Compressed air 6 bar	l/min	5
Weight	kg	1350

*HS = Hot smoking; CS = Cold smoking and maturing; BA = Baking



SCHRÖTER'S COMPACT CONCEPT: THERMICjet® HR

STRUCTURAL CHARACTERISTICS

- > Chassis and all relevant components are built to be structurally gas and steam tight
- > All components, such as insulation, motors, fans, and ducts, have the ideal dimensions

CUSTOMER BENEFITS

- > Speed
- > Homogeneity
- > Energy savings
- > Minimal weight loss
- > Quickly reach target value + accurately maintain target value
- > Consistent results
- > Accurately repeat a predefined result
- > Ideal temperature and humidity
- > Products are handled in an absolutely gentle and uniform manner



SCHRÖTER TECHNOLOGIE GMBH & CO. KG | BAHNHOFSTRASSE 86 | D-33829 BORGHOLZHAUSEN | GERMANY



Tel. +49 (0) 54 25.95 00
Fax +49 (0) 54 25.18 28

info@schroeter-technologie.de
www.schroeter-technologie.de